

MK2789S Wide VCC Range HF QR Controller with GaN Integrated

1. Description

The MK2789S is a high frequency QR controller optimized for PD/Fast charge applications. Its wide VCC operating voltage range (9V-85V) allows it to cover PD/PPS from 3.3V-21V output range without the need to use additional VCC windings or linear step-down circuits.

In order to achieve high efficiency from universal line across different load, the MK2789S is self-adaptive to operate at DCM/QR. At light load, it will work in Burst mode to improve efficiency.

The MK2789S offers various protection features including output over-voltage protection (OVP), output over power protection (OPP), VCC over-voltage protection, Brown in/out, Secondary side SR short circuit protection (SSCP), and CS short protection.

2. Typical Applications

- 45W AC/DC PD/Adapter
- High Power Density Power Supply

4. Simplified Application

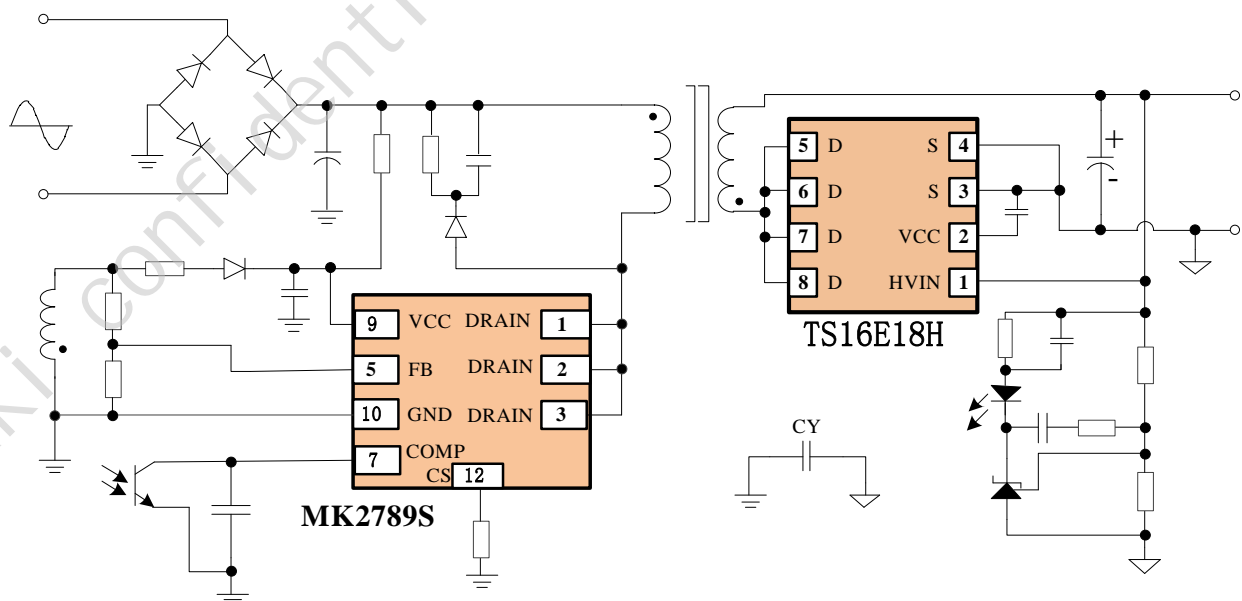

3. Features

- Built-in 700V 350mR GaN FET
- Wide VCC Operating Range(9V-85V)
- Operating Frequency up to 130kHz
- Proprietary Soft-start Scheme to Achieve Low SR Vds Stress
- Optimized Efficiency to Easily Meets Energy Efficiency Standards
- CS Short Protection
- OPP/SSCP Protection
- Brown in /Brown out Function
- VCC OVP/VO OVP Protection
- Support PPS Wide Range Output
- Tiny DFN6X8 Package

5. Ordering Information

Ordering No.	Description
MK2789SCDG	DFN6X8, 3000 pcs/reel

6. Package Reference

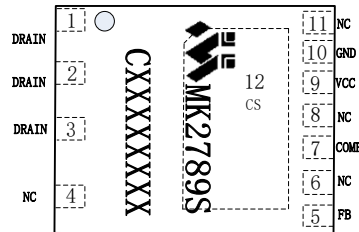

XXXXXXXX: Lot Code
DFN6X8 Top View

6.1 Absolute Maximum Ratings⁽¹⁾

VCC.....	-0.3V to +100V
COMP, FB.....	-0.3V to +5.5V
CS.....	-0.7V to +5.5V
DRAIN.....	-3V to +700V
I _D	3.3A ⁽²⁾
I _{DM}	10A ⁽³⁾
Junction Temperature	+155°C

6.2 Recommended Operation Conditions

VCC	9V to 85V
Maximum Junction Temp. (T _J).....	+125°C

6.3 Thermal Resistance⁽⁴⁾

θ _{JA}	45 °C/W
θ _{JC}	2°C/W

Notes:

- (1) Exceeding these ratings may damage the device;
- (2) T_J=125°C; The maximum continuous drain current is calculated based on the maximum allowable junction temperature;
- (3) T_c = 25 °C, T_{pulse} = 10 μs ; Limit was extracted from characterization test, not measured during production;
- (4) Measured on JE51-7, 4 layers PCB.

7. Pin Functions

Pin #	Name	Description
1、2、3	DRAIN	HV Power GaN Drain
4、6、8、11	NC	NC
5	FB	Auxiliary Voltage Sense
7	COMP	Voltage Feedback
9	VCC	Power Supply
10	GND	Ground
12	CS	Current Sense Input

8. Block Diagram

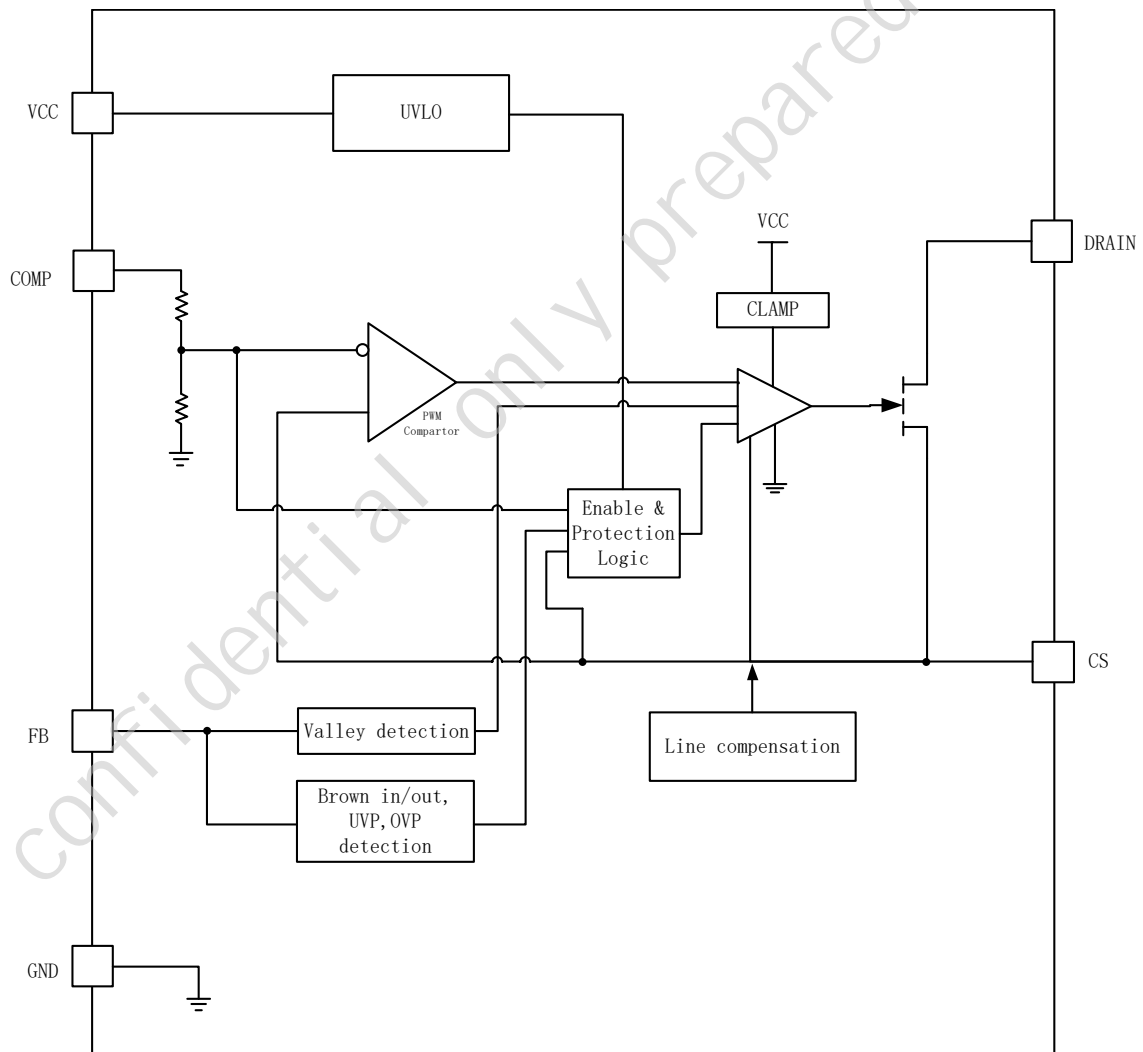

Figure 1. Functional Block Diagram

9. Electrical Characteristics

VCC=12V, T_A=25°C, unless otherwise noted.

Parameter	Symbol	Conditions	Min	Typ	Max	Units
GaN Section						
GaN Drain to Source Breakdown Voltage	V _{VDSS}		700			V
Static Drain to Source on Resistance	R _{DSON}			270	350	mΩ
Supply Management Section						
VCC UVLO Rising	V _{CC_ON}		15.5	17.2	19.9	V
VCC UVLO Falling	V _{CC_OFF}		6	7.3	8.4	V
VCC UVLO Hysteresis	V _{CC_HYST}		8.5	10	11.2	V
VCC Startup Current	I _{STARTUP}		2	5	8	uA
VCC Normal Operating Current	I _{OP}	COMP=2V	0.3	0.6	1.5	mA
Burst Operating Current	I _{BURST}	COMP=0V, GATE=1nF to GND	240	290	340	uA
VCC OVP Threshold	V _{CC_OVP}		87	93	100	V
VCC Clamp Threshold	V _{CC_CLAMP}		89	102	110	V
Comp Input Section						
COMP Open Voltage	V _{COMP_OP}	COMP Pin Open-circuited	4	4.4	4.8	V
COMP Short-circuit Current	I _{COMP_SHOR T}	COMP=0V	130	160	190	uA
Burst Mode Entry Voltage	V _{BM_ET}		0.27	0.30	0.33	V
Burst Mode Hysteresis	V _{BM_HY}		0.02	0.05	0.09	V
OPP Protection Threshold	V _{OPP}		2.8	3.0	3.2	V
OPP Deglitch Time*	T _{D_OPP}			T _{SS} *6		mS
Current Sense Input Section						
Soft Start Time of CS Threshold	T _{SS}		4	7	10	mS
Secondary Rectifier Short-circuit trigger voltage (OC FAULT)	V _{SR_SH}		1.1	1.2	1.3	V
SR Short-circuit Deglitch cycles*				3		Cycles
Cycle by Cycle Current Limit(low line)	V _{CS_CBCL}	V _{FB} <1V, I _{FB} =100uA	0.79	0.85	0.91	V

Cycle by Cycle Current Limit(high line)	V_{CS_CBCH}	$V_{FB}<1V, I_{FB}=300\mu A$	0.56	0.63	0.7	V
CS Short Protection Threshold	V_{CS_SH}			0.05		V
CS Short Deglitch cycles*	T_{CS_SH}			3		Cycles
FB Input Section						
Brown-in Detection Threshold	I_{BNI}		78	94	109	μA
Brown-out Detection Threshold	I_{BNO}		69	85	100	μA
Brown-out Deglitch Time*	T_{BL_BNO}			$T_{SS} \times 7$		mS
FB OVP Threshold	V_{FB_OVP}		3.3	3.6	3.9	V
FB OVP Deglitch Time*	T_{BL_OVP}			7		
FB UVP Threshold (Output Short)	V_{FB_ST}		0.17	0.20	0.23	V
FB UVP Threshold (Output Short) Deglitch Time*	T_{BL_ST}			7		cycles
UVP Blanking Time after SS*	T_{D_ST}			$T_{SS} \times 2$		mS
FB High Threshold	V_{FB_H}		1.7	1.9	2.1	V
FB Middle Threshold	V_{FB_M}		1	1.1	1.2	V
Control Law						
Normal Mode Frequency	F_{SW_max}		110	130	150	kHz
Green Mode Frequency	F_{SW_green}		21	25	29	kHz
Dithering Range*				± 6		%
Dithering Period*				8		mS
Maximum Toff Time	T_{off_MAX}		80	110	140	μS
Thermal Shutdown Threshold*	T_{hSD}			155		$^{\circ}C$
Thermal Shutdown Hysteresis*	T_{hSD_hys}			30		$^{\circ}C$

Note:

- (1) Guaranteed by design

10. Operation Descriptions

Vcc and Start-up

The MK2789S's start-up current $I_{STARTUP}$ is only $\sim 5\mu A$ so that a large value of start-up resistor can be used to charge up VCC while minimizing power loss during start-up. Once VCC reaches above the V_{CC_ON} ($\sim 17.2V$) threshold, the MK2789S starts switching.

Soft Start

The MK2789S features an internal soft start T_{SS} ($\sim 7mS$) to reduce electrical stress in the power system during start-up. To further reduce voltage stresses from high peak current and high frequency switching, the MK2789S operates at optimized frequencies and control modes accordingly to the output voltages and the start-up status of the synchronous rectifier controller.

Operation Curve

The MK2789S has multiple working modes, which can be switched by monitoring the voltage change of COMP. Since the voltage change of COMP is consistent with the load change, the MK2789S can automatically switch to the optimal operating mode according to different load conditions. The operation curve of the MK2789S operating mode is shown as in Figure 2:

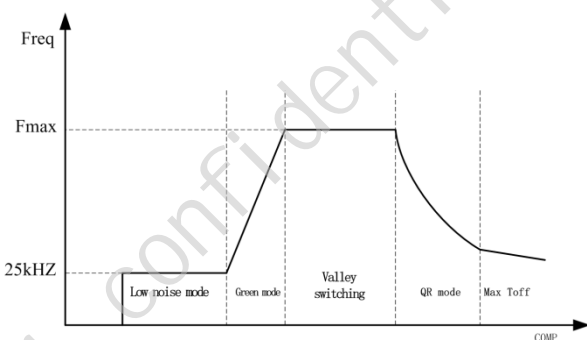

Figure 2: operation curve

Brown in/ Brown out

When the power GaN is turned on, the voltage at auxiliary windings is negative, which makes Brown-in/Brown-out protection feasible by detecting the current at FB pin. When system starts up, and the power GaN is turned on, the

current flowing out of FB pin is equal to:

$$\frac{V_{BULK} * N_a}{R_u * N_p}$$

If this current is larger than I_{BNI} for four switching cycles, the controller enables soft start. Otherwise Brown-in restart protection is triggered.

During normal operation, if the current at FB is less than I_{BNO} for at least T_{BL_BNO} ($\sim 49mS$), the controller enters Brown-out restart protection.

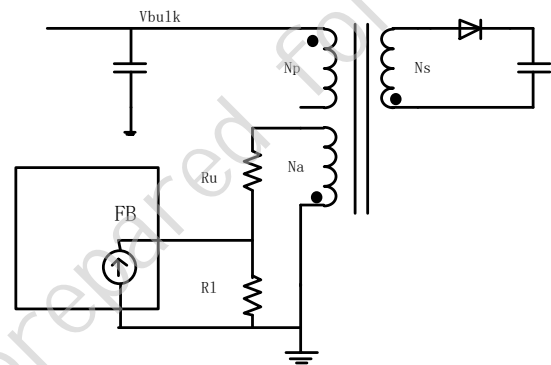

Figure 3: Brown in/Brown out

Current Sense

The MK2789S is current mode PWM controller. The voltage detected on CS pin is compared with the voltage loop feedback voltage inside the chip to determine the duty ratio. When COMP is at its maximum, the MK2789S also limits the peak current of the primary edge every switching cycle, and its maximum current limit value is V_{CS_CBC}/R_{cs} .

Due to the voltage of the drive current on the CS resistance and the influence of the converted capacitor C_{SW} on the drain node, there will be a spike in the CS resistance at the moment when the driver is switched on. This spike could false trigger PWM controller to falsely generate very narrow duty cycle pulse. Therefore, the leading-edge blanking time $\sim 300nS$ was added to the CS sampling circuit inside the chip.

Line Compensation

The MK2789S uses the detected input line voltage through the current at FB pin to generate the offset voltage added on internal current signal to compensate the output OPP power level. This mechanism helps to achieve flat OPP power level over different input voltage.

Voltage Feedback Loop

COMP is the voltage loop feedback pin which is connected to TL431 output through opto-coupler. In order to support a wide COMP range, a ratio of 1/2.5 resistor divider is used before it goes into PWM comparator.

A ceramic capacitor is suggested to be placed parallel to the resistor which is series with opto-coupler diode.

FB Voltage Detection

The MK2789S detects the transformer core demagnetization by monitoring the signal at the auxiliary windings through FB pin.

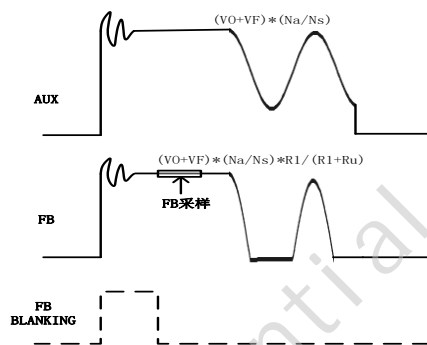

Figure 4:FB detection

After a period of demagnetization time (~1.4uS) of the transformer, the FB sampling voltage is compared with different thresholds. The MK2789S can complete the following functions:

1. Output over voltage protection (OVP): FB is above V_{FB_OVP} (~3.6V) for 7 switching cycles;
2. Output under voltage protection (output short circuit protection): FB is below V_{FB_ST} (~0.2V) for 7 switching cycles;
3. Based on the detected output voltage, the operating control curve is determined.

Valley Switching

After secondary side rectification is complete, the drain voltage starts oscillating with a frequency of approximately $\frac{1}{2} \pi \sqrt{C_{oss} \times L_p}$, where L_p is the inductance of primary winding of the transformer and C_{oss} is capacitance on the drain of primary GaN. When the oscillation ringing is below 0V at the auxiliary winding, the MK2789S clamps the FB pin to 0V, and senses the current at the FB pin. When the current out of FB reaches a designed value, a “possible” valley is locked and the MK2789S turns on after propagation delay.

Protection Function

Reliable power supply system is achieved with restart protections including cycle-by-cycle current limit, over-power protection (OPP), output over-voltage protection, etc. Detailed protection features are described in the following sessions. The MK2789S protection triggers, will stop the drive, the VCC discharge current makes the VCC capacitor voltage drop. When the VCC voltage drops to V_{CC_OFF} (~7.2V), the VCC capacitor starts charging and reaches V_{CC_ON} (~17.2V), restarting the drive and completing the restart.

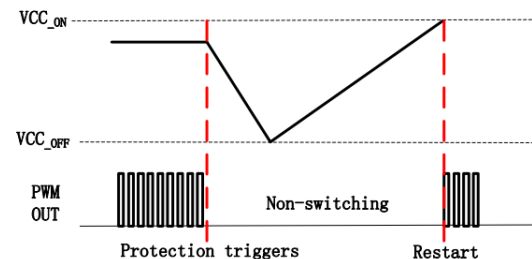

Figure 5:Restart mode

MK2789S PROTECTION FEATURES	MK2789S PROTECTION SCHEMES
OPP	RESTART
VO_OVP	RESTART
VCC_OVP	RESTART
CS_SHORT	RESTART
SSCP	RESTART
FB_UVP (VO_SCP)	RESTART

Over Power Protection

The OPP protection is achieved by monitoring COMP voltage. If COMP voltage is above V_{OPP} (~3V) for at least 6 times of soft-start time, i.e. $T_{ss} \times 6$ (~42mS), the MK2789S enters restart mode.

Cycle by Cycle Current Limiting

The current-mode controller compares the CS signal with the COMP signal cycle-by-cycle. However during an output short circuit or an open opto-coupler fault, the COMP voltage can rise excessively, leading to high peak currents and transformer saturation. To mitigate this, the MK2789S implements an additional protection scheme, which compares the CS voltage with V_{CS_CBC} cycle-by-cycle. After the blanking time of approximately 300ns, if the CS voltage reaches V_{CS_CBC} , the chip immediately halts the driver output.

Secondary Side SR Short Circuit Protection

If the secondary side synchronous rectifier is short circuited, the peak current increases rapidly after the power GaN is turned on. Therefore, the protection is needed to react in much less wait time. The MK2789S reduces current sense blanking time to 90ns when the CS pin detects a

voltage above V_{SR_SH} (~1.2V) threshold. It immediately stops the driver output. If this condition persists for three consecutive cycles, the MK2789S determines that a secondary SR short circuit has occurred, and it stops the driver and enters the restart mode.

CS Short Protection

If CS still fails to reach V_{CS_SH} (~0.05V) after 5us of primary GaN turning on, the MK2789S will force drive shutdown. If this condition occurs for three consecutive periods, the MK2789S enters restart mode.

Vcc OVP

Whenever the VCC voltage is higher than the OVP threshold voltage V_{CC_OVP} (~93V), the output gate drive circuit will be shut down to stop the switching of the power GaN, and the MK2789S enters the restart mode.

OTP

The MK2789S provides internal over-temperature protection with a trigger point of ~155°C and a hysteresis temperature of ~30°C.

11. Package Information (DFN6X8)

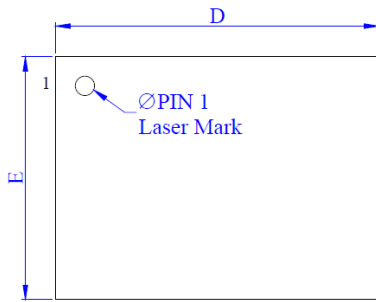

Top view

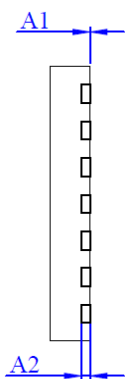

Side view

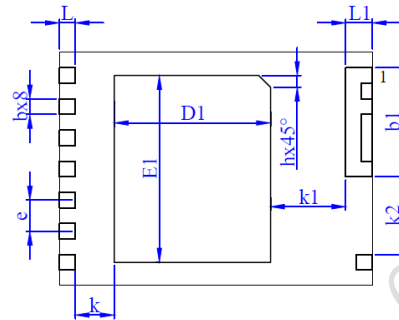

Bottom view

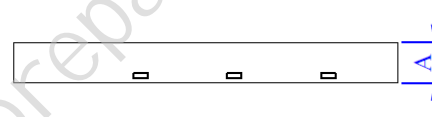

Side view

Symbol	Dimensions In Millimeters		
	MIN	NOM	MAX
A	0.80	0.85	0.90
A1	0.00	-	0.05
b	0.35	0.40	0.45
b1	2.70	2.80	2.90
D	7.90	8.00	8.10
D1	3.90	4.00	4.10
E	5.90	6.00	6.10
E1	4.70	4.80	4.90
e	0.8 BSC		
h	0.20	0.30	0.40
k	0.8 MIN		
K1	1.7 MIN		
K2	1.8 MIN		
L	0.30	0.40	0.50
L1	0.575	0.675	0.775

12. Tape and Reel Information

Device	Package Type	Pins	SPQ (pcs)	A (mm)	B (mm)	K (mm)	P (mm)	W (mm)	Pin1 Quadrant
MK2789SCDG	DFN6x8-11L	11	3000	6.3±0.1	8.3±0.1	1.0±0.1	8.0±0.1	16.0±0.3	Q2

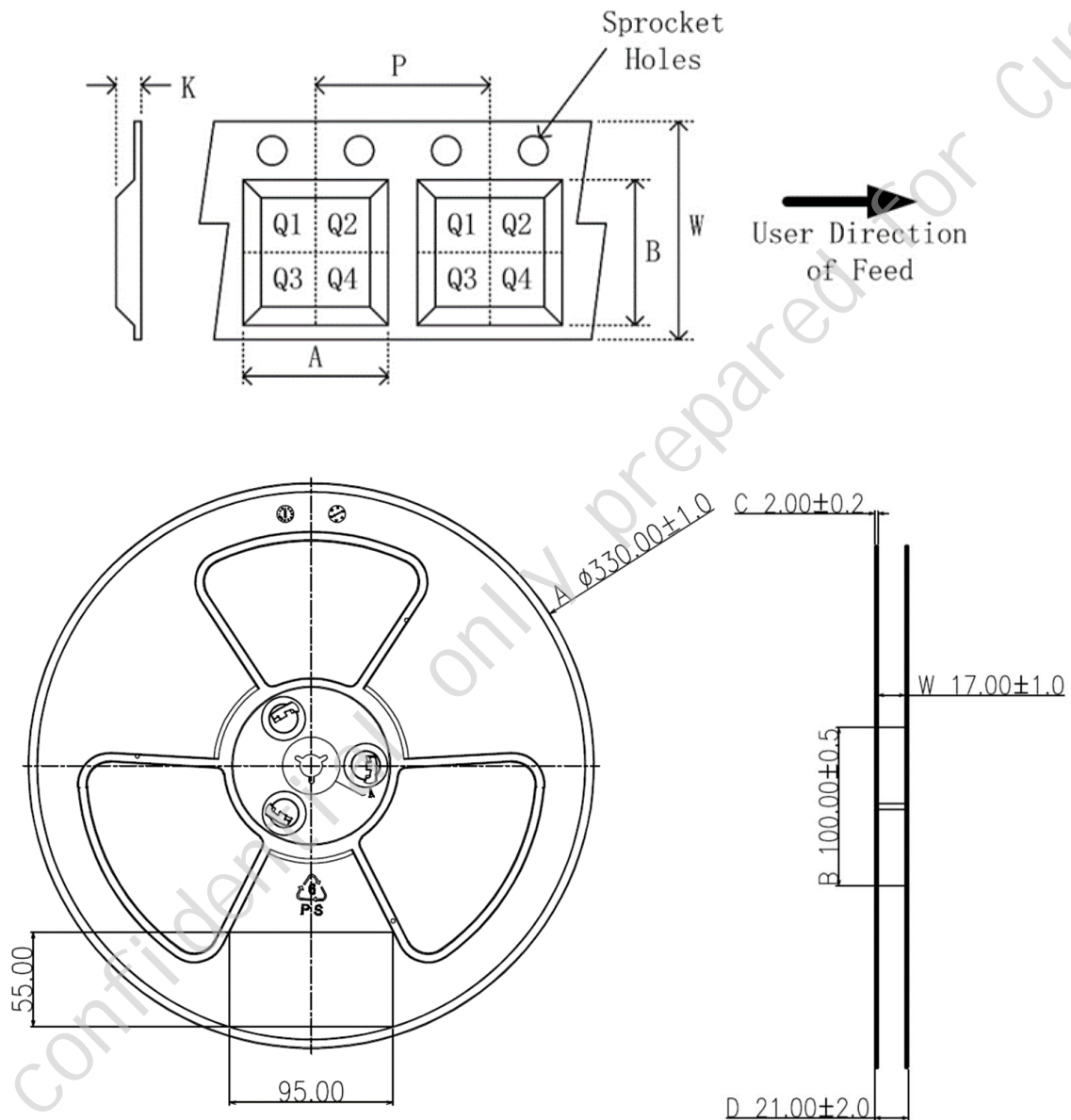

13. Tape and Reel Box Dimensions

Device	Package Type	Pins	SPQ (pcs)	Length (mm)	Width (mm)	Height (mm)
MK2789SCDG	DFN6x8-11L	11	6000	360	360	65

